

3A5K0A

5KW VHF BIII SOLID STATE TRANSMITTER

Ready for Digital

ELECTROLINK VHF BIII TRANSMITTERS LINE

3A5K0A Transmitter belongs to Electrolink medium-high power TV VHF BIII product family. Electrolink solid state TV transmitter generation covers a power range from 0,5W to 30 kW (higher output power available on request). Each transmitter includes the following components:

- Multistandard Exciter (analog and digital)
- Power Amplifiers
- Stainless steel transmitter rack with cooling system
- Power combiner
- Power distribution
- Control Logic unit (for local/remote control)
- Step-down transformers (complete protection)
- Output filter (for critical and non-critical mask)

All transmitters can boast outstanding technical parameters, optimum cost/benefit ratio, maximum reliability and ease of servicing. The transmitter can be equipped with Multistandard TV exciter (analog and digital at the same time) and also dual exciter with automatic change-over unit is available on request.

The transmitter control logic unit, equipped with a touchscreen display, can handle all the parameters and diagnostic about the equipment status and its related sub-units, providing all control functions. All transmitter and amplifier parameters required for diagnostics can be retrieved locally or remotely via standard (IP) protocol and standard software (web browser and lab-view application). Each power amplifier is self-protected and self-controlled.

Three step-down transformers, used to provide a total redundancy and protection, are mounted on slide-out wheels in order to get ease installation and maintenance operations.



3A5K0A - 5KW VHF Solid State Transmitter

KEY FEATURES

- ❑ Multistandard exciter (VHF BIII, DVB-T/H, ATSC)
- ❑ "State of the Art" solid state technology
- ❑ MOSFET transistors
- ❑ 19" standard rack clearly arranged and easily accessible
- ❑ Hotpluggable power amplifiers (with extender included)
- ❑ Ultra-high redundancy thanks to modular configuration
- ❑ Low junction temperatures of the RF transistors
- ❑ Three Step-down transformers
- ❑ Each final stage disposes of its own power supply
- ❑ Remote/local control
- ❑ Protective circuits for the RF power transistors
- ❑ High suppression of intermodulation products
- ❑ Efficient low noise forced air cooling



3A5K0A - Functional Block Diagram

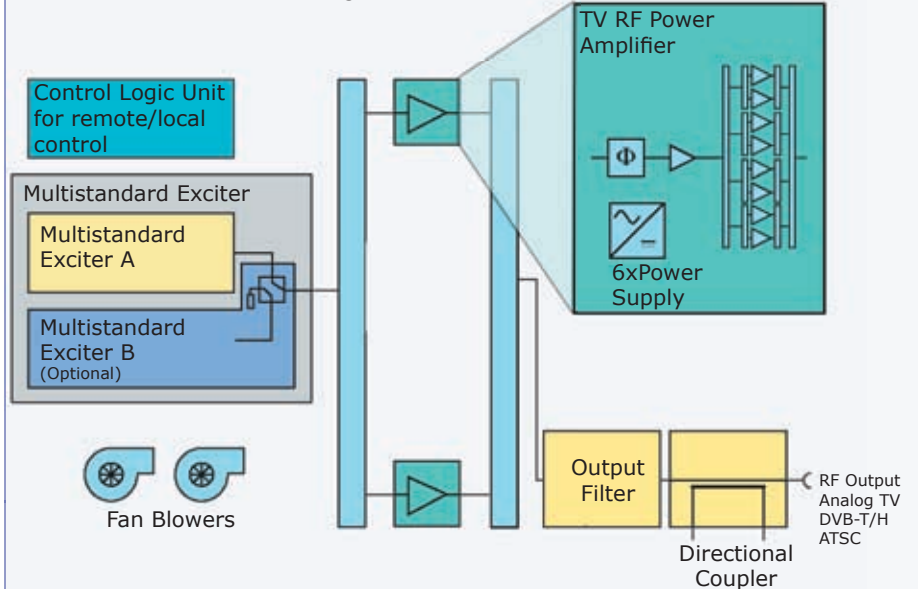

MULTISTANDARD EXCITER (Analog TV, DVB-T/H hierarchical mode, ATSC)

Rugged, compact, high performance, reliable and easy maintenance. Electrolink multistandard exciter can support any kind of TV analog or digital modulation, such as VHF BI, VHF BIII, UHF BIV-V, DVB-T/H and ATSC. Upon request, internal GPS can be provided. Thanks to this exciter, every transmitter can be switched from analog TV standard to digital standard simply by pressing a button and also via software by remote control. It can be used for SFN or MFN network and allows easy operation in any working conditions.



Completely microprocessor-controlled, it complies with all international standards. In the rear panel there are the following inputs:

- 2 data inputs (ASI/SMPTE310M) for all digital standards, in order to have redundancy at the signals input and seamless switching during switchover. As alternative, the two inputs can be used for DVB-T and DVB-H for hierarchical modulation. SFN adapter is used for data synchronization timing and an optional GPS receiver (integrated in the exciter) provides the required references
- Analog inputs for all the transmission standards (B/G, D/K, M/N and I) are implemented in the multistandard exciter. All color and sound transmission methods are available.

In few words, the multistandard exciter is the right choice for a complete independence in the analog to digital transition and it represents a sharp solution for customer investment.

POWER AMPLIFIERS Fully solid state and fully broadband all over VHF BIII (from 170 up to 240MHz). For complete redundancy, each final stage (6 final stages per each power amplifier) has its own power supply. The output power is displayed in the front panel by means of a multifunction display. 3 blowers ensure the complete cooling of the power amplifier and total redundancy. The power amplifiers can be taken out the equipment without turning off the transmitter, thanks to the already included extender: this allows personnel to work into the power amplifiers with complete output power of the transmitter and in safe conditions (only 48V).



CONTROL LOGIC UNIT Locally the transmitter can be controlled and operated via touch-screen graphical display and the front panel keypad. The operators can always know the status of the transmitter and have a complete control of the equipment. The touch-screen graphical display is very user-friendly and help monitoring all the parameters of the complete system. On the right side, a needle meter always shows the output power. In addition, the transmitter can also be remote-monitored and remote-controlled via standard (IP) protocol and standard software (web browser and lab-view application).



MAINS DISTRIBUTION In order to ensure the complete power supply voltages, the transmitter is equipped with 3 step-down isolation transformer with electrostatic shield that can guarantee 100% redundancy. In case of fault phase lack or one/two transformers fault, the transmitter keeps on working automatically reducing the output power, but not turn off at all. This allows continuous on-air condition.



TECHNICAL SPECIFICATIONS

General Information

Frequency range	170 MHz to 240 MHz
Power supply	3-phase 230 - 380 - 415Vac $\pm 15\%$ with neutral (different upon request)
Frequency	47 to 70 Hz
Max. installation altitude	2.000 m above sea level (>2000 m on request)
Operating temperature range	+0°C to +45°C
Storage Temperature	-20°C to +70°C
Permissible relative humidity	95 %, non-condensing
Dimensions (W x D x H)	580 mm x 1230 mm x 1662 mm
Weight	450KG
RF connector	1" 5/8 EIA

RF Characteristics

Output power	5kW Analog VHF BIII 1,5kW DVB-T/H 2,5kW ATSC
Power Consumption	14,5KVA (at Black Level)
Vision/Sound power ratio	10/1 single sound 20/1/0.2 dual sound
Out stage technology	solid state MOSFET
Vision - Sound amplification	Common
TV Analog System Standards	B/G, D/K, M/N, PAL, SECAM, NTSC FM Mono, Dual-Sound/Stereo, NICAM (Opt.)
TV Digital System Standards	DVB-T/H, ATSC, All ASI Modes, SMPT310M, hierarc.mod. for DVB-T/H
Modulation class	C3F, F3E
Sound transmission	FM single-sound, dual-sound coding IRT, NICAM 728
Harmonics emission	≤ 1 mW
Spurious emission	≤ 1 mW
Frequency stability	± 200 Hz / 6 months or ± 2 Hz / month (option)
External drive frequency	10 MHz, 0,1V \div 5V (V_{pp}) or TTL / 1pps TTL (Ref. Pulse)
Offset capability	25 Hz step up to ± 24 kHz

Vision

Video input	BNC 75 Ω connector
Nominal input level	1 Vpp ± 6 dB
Return loss	≥ 30 dB
DC restoration	clamped to the blanking level without affecting the burst
White limiter	at 90% picture signal without affecting the chrominance

Transmission Characteristics

Sideband spectrum response	according to the standard
Amplitude-frequency response	according to the standard
Non linearity dist. (10 to 75% mod.)	≤ 5 %
Differential gain (10 to 75% mod.)	≤ 5 %
Differential phase (10 to 75% mod.)	$\leq \pm 3^\circ$
Signal to hum ratio ($f \leq 1$ kHz)	≤ 50 dB
Signal to random noise ratio	≥ 56 dB (unweighted 0.2 to 5 MHz) - ≥ 60 dB (weighted 10Khz to 5 MHz)
Blanking level variation	$\leq 2\%$
2T k factor	$\leq 2\%$
Power factor	≥ 0.9
ICPM (picture range)	$\leq 2^\circ$
Intercarrier S/N ratio	≥ 50 dB (referred to ± 50 kHz deviation)
Intermodulation products	≤ 60 dBc

Local and Remote Control

Local control	Touch-screen graphical display and front-panel keypad operation via user interface via standard Web browser
Remote control	via Ethernet, standard Web server and/or SNMP agent (optional) Lab-view environment



Via delle Acacie - 05018 ORVIETO (TR) ITALY

General Information

electrolink@electrolink.com

Phone +39 0763 30 55 30

Fax +39 0763 39 03 66

Sales & Marketing

sales@electrolink.com

Phone +39 328 92 57 478

Phone +39 328 73 64 750

Fax +39 0763 39 03 66

Ventas y Comercialización

ventas@electrolink.com

Tel. +39 328 92 57 478

Fax +39 0763 39 03 66



UNI EN ISO 9001:2000 certified company
Registration Number: IT - 8848

