

# 2K4

## 4KW FM BII SOLID STATE TRANSMITTER

### ELECTROLINK FM BII TRANSMITTERS LINE

2K4 Transmitter belongs to Electrolink medium power FM product family. Electrolink FM air-cooled transmitter generation covers a power range from 50W to 40 kW (higher output power available on request up to 100kW). Each transmitter includes the following components:

- Exciter (analog or digital available)
- Power Amplifiers (horizontal and vertical line)
- Stainless steel transmitter rack with cooling system (from 12HE up to 36HE)
- Power combiner
- Power distribution
- Control unit (for local/remote control)
- Step-down transformers (complete protection).

All transmitters can boast outstanding technical parameters, optimum cost/benefit ratio, maximum reliability and ease of servicing. The transmitter can be equipped with analog or digital FM exciter and also dual exciter with automatic change-over unit is available on request.

The power amplifier control unit can handle and display all the parameters and diagnostic about the equipment status, providing all control functions. All transmitter and amplifier parameters required for diagnostics can be retrieved locally or remotely via standard (IP) protocol and standard software (web browser and lab-view application). Each power amplifier is self-protected and self-controlled.

Three step-down transformers, used to provide a total redundancy and protection, are mounted on slide-out wheels in order to get ease installation and maintenance operations.



2K4 - 4KW FM Solid State Transmitter

### KEY FEATURES

- ❑ Analog or digital exciter
- ❑ "State of the Art" solid state technology
- ❑ MOSFET transistors
- ❑ 19" standard rack clearly arranged and easily accessible
- ❑ Ultra-high redundancy thanks to modular configuration
- ❑ Low junction temperatures of the RF power transistors
- ❑ Three Step-down transformers for complete protection
- ❑ Each final stage disposes of its own power supply unit
- ❑ Remote/local control
- ❑ Protective circuits for the RF power transistors
- ❑ High suppression of intermodulation products
- ❑ Efficient low noise forced air cooling

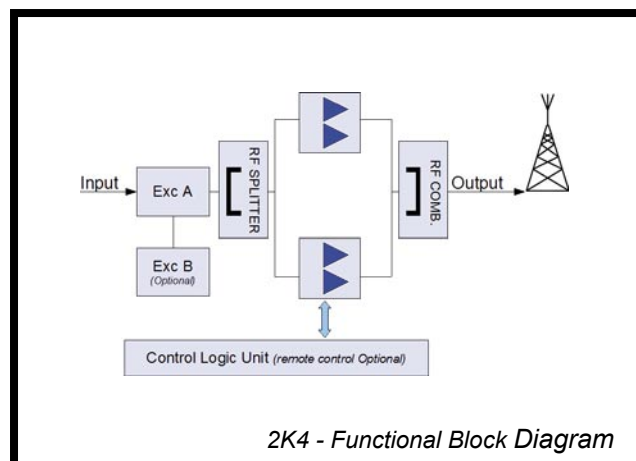

2K4 - Functional Block Diagram

## 2K4 - TECHNICAL DATA

Frequency range	87.5 to 108 MHz
Output Power	4kW
Homologation RF-AF performances	ETSI ETS 300 384
Homologation EMC standard	ETSI ETS 300 447
Homologation safety standard	UNI EN 60215
RF Output connector	7/8" EIA
Input/Output impedance	50Ω
Harmonic suppression	>80 dB
Intermodulation products	<1μW
Remote control	via serial interface RS232
Power Supply:	Single-phase 230V Three-phase 230 - 380 - 415Vac ±15% with neutral 47 to 70 Hz
RF Input Connectors	N type
Input driver power	80W
Power consumption	7kVA (all included)
Power factor cos .	≥0.95
Harmonic and spurious suppression	meet or exceed all CCIR & FCC req.
Dimensions (mm)	550 x 950 x 1130(H)
Weight	240Kg
Ambient temperature	- 5 to +45°C
Storage temperature	-20 to +70°C
Humidity	95 % (non-condensing)
Installation height	up to 2.000 m (asl)



**EXCITER** High performance, compact, reliable and easy maintenance. Adjustable output power from 0W to maximum power with automatic APC control and protection. Safe operation in any working conditions. Completely microprocessor-controlled. It complies with all EC, FCC and CCIR standards. In addition to the analog exciters, Electrolink can also provide Digital FM exciters in order to avoid the needing for analog up-conversion, noise and filtering requirements, bringing up to digital quality standards at very low distortion.



**POWER AMPLIFIERS** 2K4 Transmitter is equipped with 2 Fully solid state and fully broadband all over FM Band (from 87.5 up to 108MHz) power amplifiers. For complete redundancy, each final stage (4 final stages per each power amplifier - as showed in the picture here below) has its own power supply. The outpower is displayed in the front panel by means of a multifunction display. 2 redundant blowers ensure the complete cooling of the power amplifier.



Note: higher output power available on request - Max 100KW

TRANSMITTER MODEL	OUTPUT POWER	NUMBER OF POWER AMPLIFIERS	DUAL EXCITER (OPTION)
Orchestra	0-250W	-	YES
2K0.5	500W	1 (HORIZONTAL)	YES
2K1	1KW	1 (HORIZONTAL)	YES
2K2	2KW	1 (HORIZONTAL)	YES
2K3	3KW	2 (HORIZONTAL)	YES
2K4	4KW	2 (HORIZONTAL)	YES
2K5	5KW	2 (HORIZONTAL)	YES
2K10	10KW	3 (VERTICAL)	YES
2K20	20KW	6 (VERTICAL)	YES
2K30	30KW	9 (VERTICAL)	YES
2K40	40KW	12 (VERTICAL)	YES

**MAINS DISTRIBUTION** In order to ensure complete the power supply voltages, the transmitter is equipped with 3 step-down isolation transformer with electrostatic shield that can guarantee 100% redundancy. In case of fault phase lack or one/two transformers fault, the transmitter keeps on working automatically reducing the output power, but not turn off at all. This allows continuous on-air condition

